

PART NUMBER	ENGINEERING NUMBER	MOUNT OPTION	PLATING	MAT'L.
39-31-1032	5569-03A4-BL	4	BLANK	BL
39-30-3031	5569-03A3	3	BLANK	BLANK
39-30-4039	5569-03A3GS2	3	15 GOLD	
39-30-4037	5569-03A3GS	3	30 GOLD	
39-30-4035	5569-03A3G2	3	15 GOLD	
39-30-3033	5569-03A3G	3	30 GOLD	
39-30-3035	5569-03A4	4	BLANK	
39-30-4033	5569-03A4GS2	4	15 GOLD	
39-30-4031	5569-03A4GS	4	30 GOLD	
39-30-3039	5569-03A4G2	4	15 GOLD	
39-30-3037	5569-03A4G	4	30 GOLD	
39-30-6039	5569-03A3S	3	TIN/NICKEL	
39-30-7031	5569-03A4S	4	TIN/NICKEL	BLANK
39-30-3032	5569-03A3-210	3	BLANK	210
39-30-5030	5569-03A3GS2-210	3	15 GOLD	
39-30-4038	5569-03A3GS-210	3	30 GOLD	
39-30-4036	5569-03A3G2-210	3	15 GOLD	
39-30-3034	5569-03A3G-210	3	30 GOLD	
39-30-3036	5569-03A4-210	4	BLANK	
39-30-4034	5569-03A4GS2-210	4	15 GOLD	
39-30-4032	5569-03A4GS-210	4	30 GOLD	
39-30-4030	5569-03A4G2-210	4	15 GOLD	
39-30-3038	5569-03A4G-210	4	30 GOLD	
39-30-7030	5569-03A3S-210	3	TIN/NICKEL	
39-30-7032	5569-03A4S-210	4	TIN/NICKEL	
50-34-8577	5569-03A4MS-210	4	MATTE TIN	210
NO E.D.P.	5569-03A5	5	BLANK	BLANK
NO E.D.P.	5569-03A5GS2	5	15 GOLD	
NO E.D.P.	5569-03A5GS	5	30 GOLD	
NO E.D.P.	5569-03A5G2	5	15 GOLD	
NO E.D.P.	5569-03A5G	5	30 GOLD	
NO E.D.P.	5569-03A5S	5	TIN/NICKEL	BLANK
NO E.D.P.	5569-03A5-210	5	BLANK	210
NO E.D.P.	5569-03A5GS2-210	5	15 GOLD	
NO E.D.P.	5569-03A5GS-210	5	30 GOLD	
NO E.D.P.	5569-03A5G2-210	5	15 GOLD	
NO E.D.P.	5569-03A5G-210	5	30 GOLD	
39-34-3037	5569-03A5S-210	5	TIN/NICKEL	210

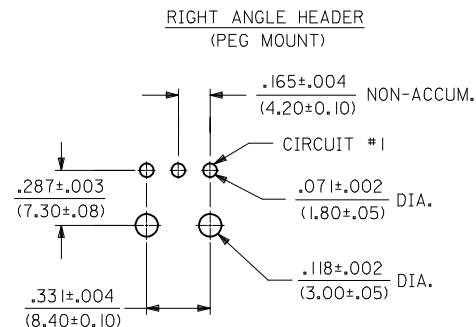
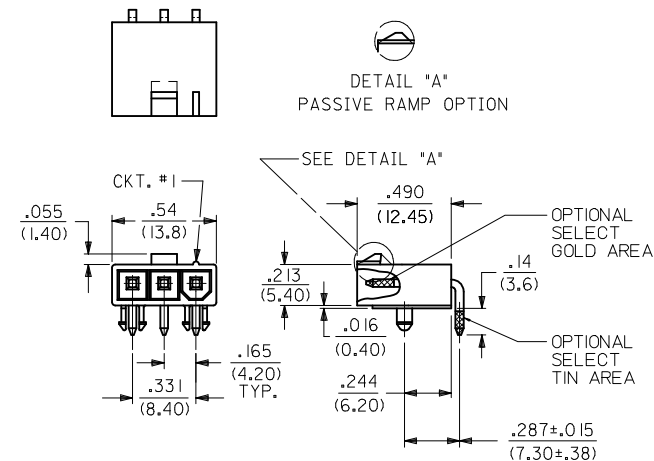
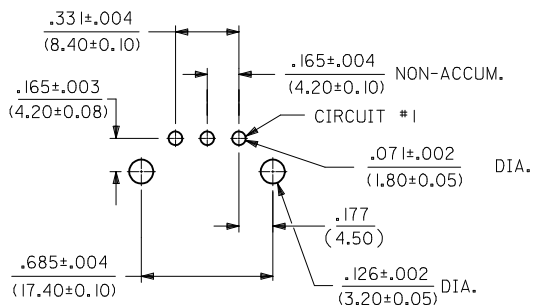
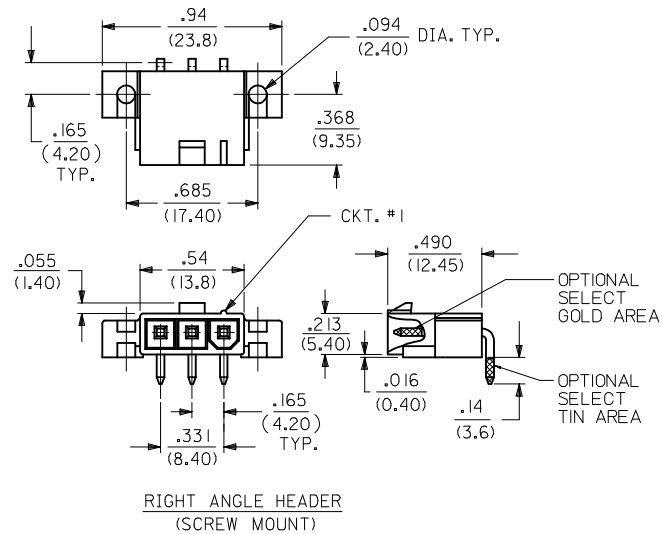

**NOTES:**

- HOUSING MATERIAL:  
 "BLANK" = NYLON 6/6, U.L. 94V-2, COLOR: NATURAL.  
 210 = NYLON 6/6, U.L. 94V-0, COLOR: NATURAL.  
 BL = NYLON 6/6, U.L. 94V-2, COLOR: BLACK.
- PART MATES WITH MOLEX RECEPTACLE #5557.
- TERMINAL MATERIAL: BRASS, ALLOY
- TERMINAL PLATING:  
 "BLANK" - .000200/(.00508) MIN. BRIGHT TIN OVER .00100/(.00254) MIN. COPPER OVERALL.  
 G - .000030/(.00076) MIN. GOLD OVER .000050/(.00127) MIN. NICKEL OVERALL.  
 G2 - .000015/(.00038) MIN. GOLD OVER .000030/(.00076) MIN. NICKEL OVERALL.  
 S - .000100/(.00254) MIN. BRIGHT TIN OVER .000050/(.00127) MIN. NICKEL.  
 MS - .000100/(.00254) MIN. MATTE TIN OVER .000050/(.00127) MIN. NICKEL

- PART IS DESIGNED FOR USE WITH 4 - 40 OR M3 SCREWS.
- DISCOLORATION IN THE BANDOLIERS CARRIER AREA OF THE PIN IS INHERENT TO THE PLATING PROCESS AND IS DUE TO THE MASKING EFFECT OF THE CARRIER. THIS DISCOLORATION IS IN A NON-FUNCTIONAL AREA OF THE PIN AND WILL NOT AFFECT THE PERFORMANCE OF THE HEADER ASSEMBLY.
- CONNECTORS ARE NOT BE MATED OR UNMATED WHILE CIRCUITS ARE LIVE.
- PARTS ARE NOT DESIGNED FOR CURRENT SHARING.
- PART CONFORMS TO CLASS "B" REQUIREMENTS OF COSMETIC SPECIFICATION PS-45499-002.

**LEGEND**

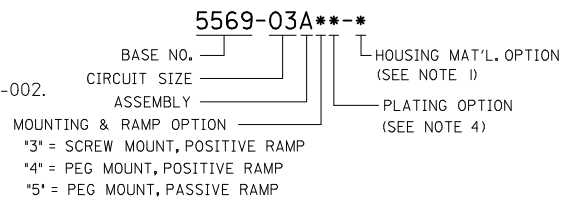

\*GS - .000030/(.00076) MIN. SELECT GOLD, .000100/(.00254) MIN. SELECT MATTE TIN OVER .000050/(.00127) MIN. NICKEL OVERALL.  
 \*GS2 - .000015/(.00038) MIN. SELECT GOLD, .000100/(.00254) MIN. SELECT MATTE TIN OVER .000050/(.00127) MIN. NICKEL OVERALL.  
 \*THE PRIMARY SHIPPING CARTON WILL BE LABELED "COMPLIANT TO RoHS DIRECTIVE 2002/95/EC AND ELV ANNEX II OF DIRECTIVE 2000/53/EC." CARTONS WITHOUT THIS LABEL MAY CONTAIN PRODUCT WITH TIN-LEAD PLATING.  
 5) PRODUCT SPECIFICATION AND PROCESSING PARAMETERS: SEE PS-5556-001

ADDED 50348577 EC NO: UCP2009-1190 DRAWN: JLOSTHEIMER 2008/11/11 CHKD: JIBELL 2008/11/13 APPR: FSM/TH 2008/11/14	QUALITY SYMBOLS ▽=0 ▽=0	GENERAL TOLERANCES (UNLESS SPECIFIED)	DIMENSION STYLE IN/MM	SCALE 1:1	DESIGN UNITS METRIC	THIRD ANGLE PROJECTION
		4 PLACES ± --- ± --- 3 PLACES ± --- ± .010 2 PLACES ± 0.25 ± .015 1 PLACE ± 0.38 ± --- ANGULAR ± 3°	DRAWN BY GEP 9/20/90 CHECKED BY RJF 9/20/90 APPROVED BY RAS 9/20/90	DATE 9/20/90	TITLE RIGHT ANGLE HEADER ASSY, 3 CKT., SINGLE ROW, MINI-FIT JR. SERIES	MATERIAL NO. SEE CHART
DRAFT WHERE APPLICABLE MUST REMAIN WITHIN DIMENSIONS		THIS DRAWING CONTAINS INFORMATION THAT IS PROPRIETARY TO MOLEX INCORPORATED AND SHOULD NOT BE USED WITHOUT WRITTEN PERMISSION				